

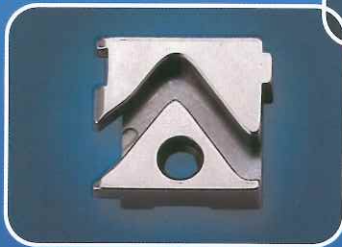

E-HWA

E-HWA COMPANY LTD.

**KNITTING M/C SPARE PARTS**

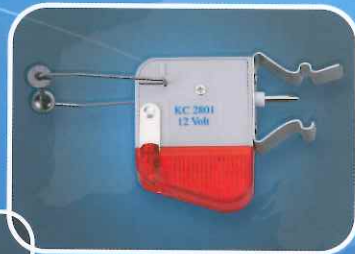

**Version 19**



CMI-266864.1



CMI-274078.4



CMI-260593.0



CMI-MY004



CMI-1313780



CMI-1316115



CMI-VG-052-23



CMI-VG452



CMI-10101103



CMI-OR042N



CMI-OR013



CMI-TOM-705-CO-6



CMI-478-521AA30



CMI-478-524AA30



CMI-478-531AA30



CMI-478-533AA30



CMI-478-623AA30



CMI-478-624AA30



CMI-3114-5251BB



CMI-4512AB30

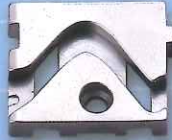

CMI-603531B30

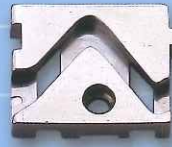

CMI-603-531-30S2



CMI-603-532-30S2



CMI-603-533-30S2



CMI-560-511-26



CMI-791511C38



CMI-791512C38



CMI-790511S2



CMI-79051230S2



CMI-7901F30S2



# CAMS

Much more... Variety of Cams supplied upon request.  
Pls send inquiries with Drawings or Samples.



CMI-211514AA38-2



CMI-211521AA38



CMI-211611AA38



CMI-211614AA38



CMI-3144-514AA30



CMI-790-511WS2-30



CMI-59-514-30S2



CMI-59-521



CMI-59-525V30



CMI-59-621-30



CMI-59-615V



CMI-59-616V



CMI-59-619-30S2



CMI-59-614B-30S2



CMI-59-612



CMI-603641AL



CMI-605501-30



CMI-605502-30



CMI-278521A30



CMI-278521BA30



CMI-278522AB30



CMI-278523A30



CMI-278524AB30



CMI-278-525AB30



CMI-278623A30



CMI-278624A30



CMI-278627A30



CMI-278628A30



CMI-278632BA30



CMI-278-633A30



CMI-58221H



CMI-58221HL



CMI-58253138



CMI-58253238



CMI-58021C



CMI-95B-551-18S2





EPZ-FKM-0515-BL   EPZ-071812-BL   EPZ-6202-EBL   EPZ-6202-WAL   EPZ-6202-W-BL   EPZ-XLFW2-001   EPZ-803



EPZ-YCM-283BA-1R   EPZ-YCM-283BA-2   EPZ-6202-E   EPZ-6202-W   EPZ-6202-WA   EPZ-6202-EC-1   EPZ-7200 (72F)  
EPZ-8400 (84F)



EPZ-YCM-345AA   EPZ-EST-07014AA   EPZ-FK001-DB   EPZ-7-1   EPZ-YCM-187J   EPZ-104MT (42L)  
EPZ-104MT-1 (50.5L)   EPZ-104T1 (42L)  
EPZ-104T1-1 (50.5L)



EPZ-YCF-112G   EPZ-112CM   EPZ-97CA   EPZ-97CA+S   EPZ-YCF-97F-A   EPZ-YCF-97F-A+S   EPZ-LEC001

# ZIRCONIA YARN CARRIERS

You may also send inquiry with Drawing, Specification or Sample.



EPZ-MXC001



EPZ-VLEC-0



EPZ-VLEC-02



EPZ-YD65-152JA



EPZ-YCF-148HA



EPZ-YCF-136AA



EPZ-YCF-124A



EPZ-34108



EPZ-3484



EPZ-3472



EPZ-897B



EPZ-VG-435-301



EPZ-04501B



EPZ-04501B-LH



EPZ-MY2547582



EPZ-03103B



EPZ-MY3634140



EPZ-MY3667250



EPZ-2943870



EPZ-2943870B  
(FOR INLAY)



EPZ-04071



EPZ-TR144



EPZ-UP372B



EPZ-TR050307



EPZ-TR005A



EPC-30205950



EPZ-186100-1





EPI-HLDR-004-CPL



EPI-VLEC-0



EPI-VLEC-02



EPI-YCF-136BA



EPI-FXZ



EPI-YCM-109C



EPI-YCF-112G



EPI-YCF-112J



EPI-97CA



EPI-97CA-C



EP-7-Y



EPI-YCM-193



EPI-187J



EPI-HLDR-003-CPL



EPI-MAY0323A



EPI-MT003



EPI-270751.0



EPI-MAY242300.2



EPI-MY009A



EPI-MY008-1



EPI-MY007-1



EPI-267651.0



EPI-MAY2434.0



EPI-KY003



EPI-JBC002



EPI-OR-322



EPI-VG-0913



EPI-VG-9702



EPI-TR050307B-1

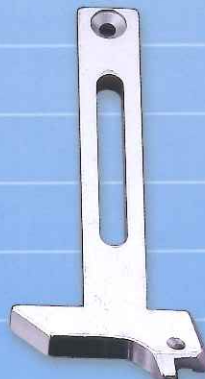

EPI-TR002



EPI-PI-1226-E



EPI-E130-3203T



# LYCRA ROLLERS & YARN GUIDES

						
ERB-4 (12x5) ERBS-4 (10x5) (W/ Bearing)	ERBS-001 (10x5) (W/ Bearing)	ERBS-007 (10x5) (W/ Bearing)	ERB-006 (12x5) (W/ Bearing)	J3214-E (18x8)	CI-LW002 (15x6)	CI-LW001 (12x5)
						
EPD-4 (12x5) EPDS-4 (10x5)	EPD-071812 (12x5)	EPDS-3 (10x5)	EPD-2 (12x5) EPDS-2 (10x5)	EPDS-1030-A (10x5)	EPDS-1544-U (10x5)	EPD-C-1.5 (12x5)
						
EPD-B (12x5) EPDS-B (10x5)	EPD-U (12x5) EPDS-U (10x5)	EPD-WHL (12x5) EPDS-WHL (10x5) (ID:2.0 or 1.5MM)	EPD1-WHL (12x5) (ID:2MM)	J3214-WHL (12x5) J3214S-WHL (10x5) (ID:2.0 or 1.5MM)	EPI-HLDR-010+L (12x5)	EP-1 (10x5)
						
EPND-1 (10x5) ERND-1 (W/ Bearing)	EPND-27R (10x5)	EPU-29 (13x6)	EPU-1530-P (13x6)	EPI-BKT-A1 (13x6)	EPA-WHL (V-GROOVE) EPU-WHL (U-GROOVE) (13x6)	POST-8 (M4*5*35) POST-9 (M4*5*30)
						
KH-B	KH-BS	EPI-HLDR-S	BKT-10MA	BKT-10S	BKT-10L	EPI-HLDR-MY
						
KH-DK	KH-DS	EPI-BKT-L2	EPI-BKT-R2	EPI-BKT-5703XA	EPI-BKT-112B	KI007A
						
					EPI-BKT-78640B	EPI-BKT-283 EPI-BKT-283-M



## POSITIVE FEEDERS



ESF N2TZ28A 2-TOOTHED WHEEL  
ESF N2PZ28A 2-PUNCHED WHEEL  
(12V or 24V) (W/ 0.8mm MYF-005)



ESF N2TZ28C 2-TOOTHED WHEEL  
ESF N2PZ28C 2-PUNCHED WHEEL  
(12V or 24V) (W/ MYF-006)



ESF N2TZ28E 2-TOOTHED WHEEL  
ESF N2PZ28E 2-PUNCHED WHEEL  
(12V or 24V) (W/ CI-WR003A)

## WIRES



IASF-WIRE 4-CORE



ER-1-WIRE 2-CORE (50m/Roll)

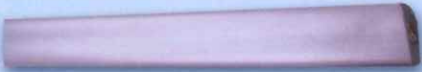

ER-1A-WIRE 1-CORE (50m/Roll)



EPF-WIRE



J507-10 INSULATED CONDUCTOR RAIL  
(10m/Roll)



ECF 2P3A



ECF-003S Green (41×14×0.5)

ECF-003S2 Green (47×18×0.5)

ECF-003S2B Black (47×18×0.6)



KI119B

EFW N2T22 2-TOOTHED WHEEL  
EFW N2P22 2-PUNCHED WHEEL  
(12V or 24V) (W/ 0.8mm MYF-005)

EFW N2T22K 2-TOOTHED WHEEL  
EFW N2P22K 2-PUNCHED WHEEL  
(W/ KI119B)

## INTERMITTENT AUTOMATIC STORAGE FEEDERS



TENSION RINGS

KC4045-B  
(BLACK)

KC4045-G  
(GREEN)

KC4045-C  
(BROWN)

KC4045-Y  
(YELLOW)

KC4045-R  
(RED)

KC4045-P  
(PINK)



IASF-1500A



KC1309



# MAGNETIC DISCS & OTHER PARTS

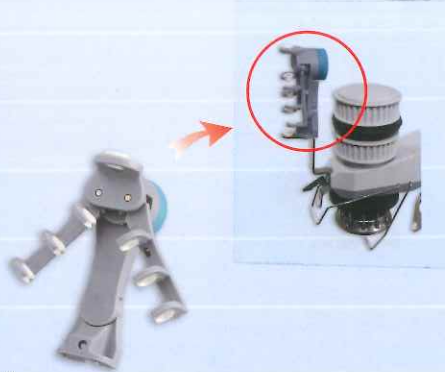

KI119  
KI119B (W/ 74MM BRACKET)

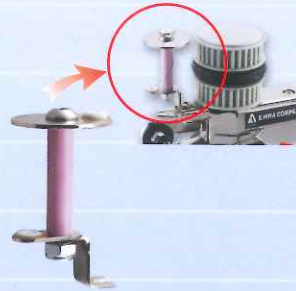

KC1319



EPF-YA01C (L:40mm)  
EPF-YA02C (L:62mm)  
EPF-YA03C (L:92mm)

EPF-YA20LC



KC1314



KC1303-1



KI006



CI-WR003A



CI-WR003



KC1314-DISC  
(ID:9.5mm)



KC1314-DISC1  
(ID:11.2mm)



KC1314-DISC3  
(ID:9.5mmW/Nylon Rings)



KC1314C-DISC  
(ID:9.6mm)



EPF-WIRE-THRD-M



JIF-12-006



JIF-12-006C



DCM24256  
(ID:5.6mm)



DCM24256-M  
(ID:5.6mm)



C-W6223W00  
(ID:5.3mm)



EPF-005  
(0.4/0.6/0.8/1.0/1.2mm in one)



EPF-007



MYF-009  
(0.3/0.4/0.5/0.6/0.8/1.0mm)



MYF-009L  
(0.4/0.5/0.6/0.8mm)



MYF-008

## (Round Tubes)

E3014AN21  
(3.0×2.1×14)

E3023A.16  
(3.0×1.6×23)

C-E2525A16  
(2.4×1.6×25)

E2730A.16  
(2.7×1.6×30)

## (Half Tubes)

C-E3015S20A  
(3×2×15)

C-E2728W17A  
(2.7×1.7×28)



MYF-005  
(0.4/0.5/0.6/0.8/1.0/1.2mm)



MYF-006



MYF-006-L



MYF-007  
(0.4/0.5/0.6/0.8/1.2mm)



## LYCRA FEEDERS

(Default Direction: Counterclockwise)

(W/ KC2801B 12V  
or KC2802B 24V)

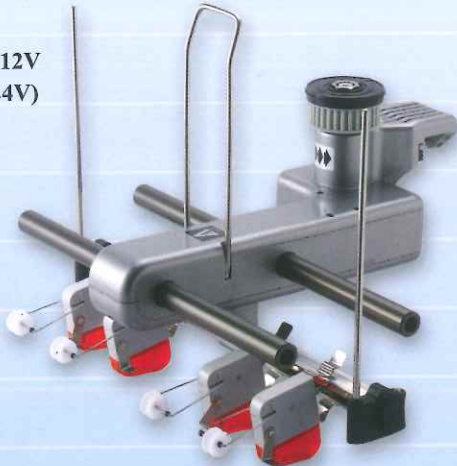

ER-1T 12V-B (TOOTHED WHEEL)  
ER-1T 24V-B (TOOTHED WHEEL)  
ER-1P 12V-B (PUNCHED WHEEL)  
ER-1P 24V-B (PUNCHED WHEEL)

(W/ KC2801C 12V  
or KC2802C 24V)

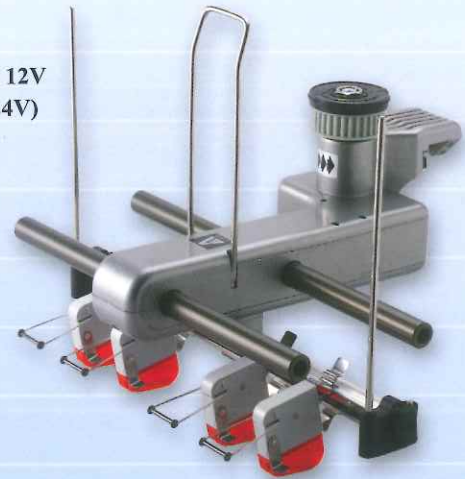

ER-1T 12V-B4 (TOOTHED WHEEL)  
ER-1T 24V-B4 (TOOTHED WHEEL)  
ER-1P 12V-B4 (PUNCHED WHEEL)  
ER-1P 24V-B4 (PUNCHED WHEEL)

## POSITIVE FEEDING DEVICES



JIF-12-003P (Φ10mm 15T)  
JIF-12-003P-B (W/ Metal Cover)  
JIF-12-003P-T (W/ Cap)



JIF-12-002M (Φ10mm 30T)  
JIF-12-002M-B (W/ Metal Cover)  
JIF-12-002M-T (W/ Cap)



JIF-12-001M (Φ10mm Single)  
JIF-12-001-1M (Φ10mm Double)

## TAPE VULCANIZERS & BELTS



PUNCHED  
J105 220V  
J106 110V



KC4046-G (10cc)  
KC4046-G500 (500cc)



KC4046  
(100m/Roll)



KC4047  
(100m/Roll)



TOOTHED  
J107 220V  
J108 110V

HEATER:  
J107-HTR 220V  
J108-HTR 110V  
J107-HTR-E 220V(EUR-Plug)



KC4048 (KEYLAR)  
(Size: 4.8m, 5.0m, 5.2m, ..., 12m per Roll)



KC4050G (KEYLAR)  
(80m per Roll)



# LYCRA/YARN STOP MOTIONS



KC2801B (12V)  
KC2802B (24V)  
(W/JFER-W1)



KC2801C (12V)  
KC2802C (24V)  
(W/JFER-W4)



J5011 12V  
J5012 24V



J5015 12V  
J5016 24V



J5017 12V  
J5018 24V  
(ESF)



KC2701-C



JFER-W



JFER-W1



JFER-W4



JFER-W3

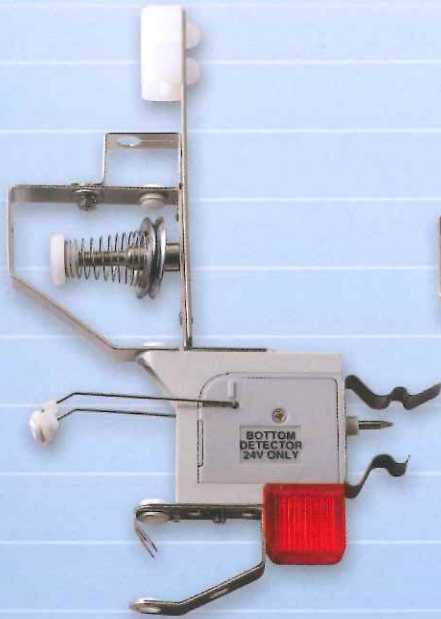

KC2911 (12V)  
KC2912 (24V)

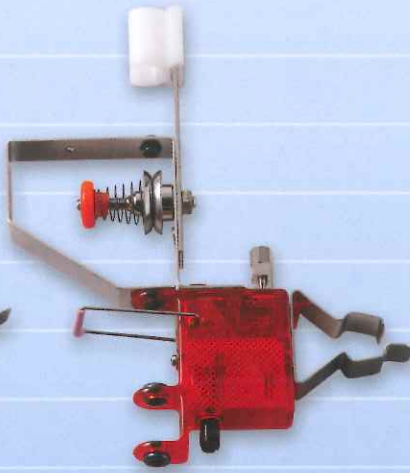

ESJ-2431P2 12V  
ESJ-2432P2 24V



KC503 12V  
KC504 24V  
KC505 12V (Pin)  
KC506 24V (Pin)



ESJ-1161 12V  
ESJ-1162 24V  
ESJ-1163 12V (Pin)  
ESJ-1164 24V (Pin)

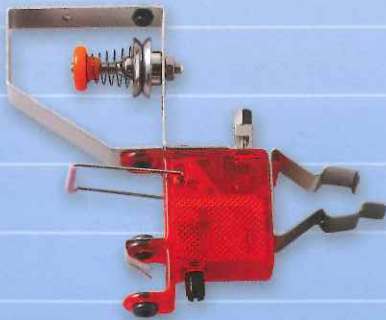

ESJ-2431PV 12V  
ESJ-2432PV 24V

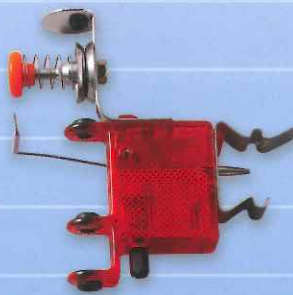

ESJ-2711 12V (Pin)  
ESJ-2712 24V (Pin)



ESJ-331A 12V (10x20 Clip)  
ESJ-331B 24V (10x20 Clip)  
ESJ-332A 12V (3x25 Clip)  
ESJ-332B 24V (3x25 Clip)

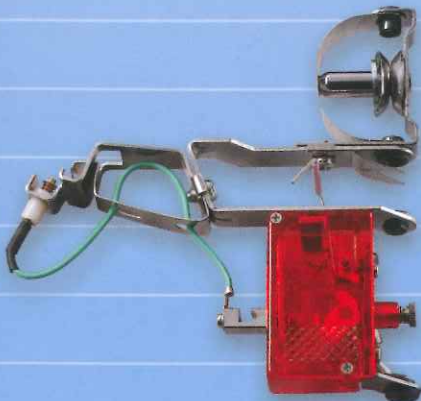

ESJ-363B 8V



KC603 12V  
KC604 24V  
KC605 12V (2-Pin)  
KC606 24V (2-Pin)  
(W/ Knot catcher)



KC603B 12V  
KC604B 24V  
KC605B 12V (2-Pin)  
KC606B 24V (2-Pin)

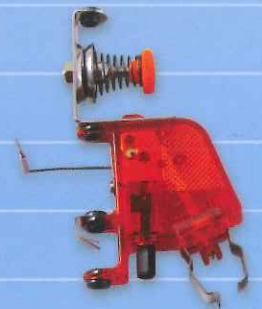

ESJ-2533VL 12V  
ESJ-2534VL 24V



# NEEDLE DETECTORS



KC3220

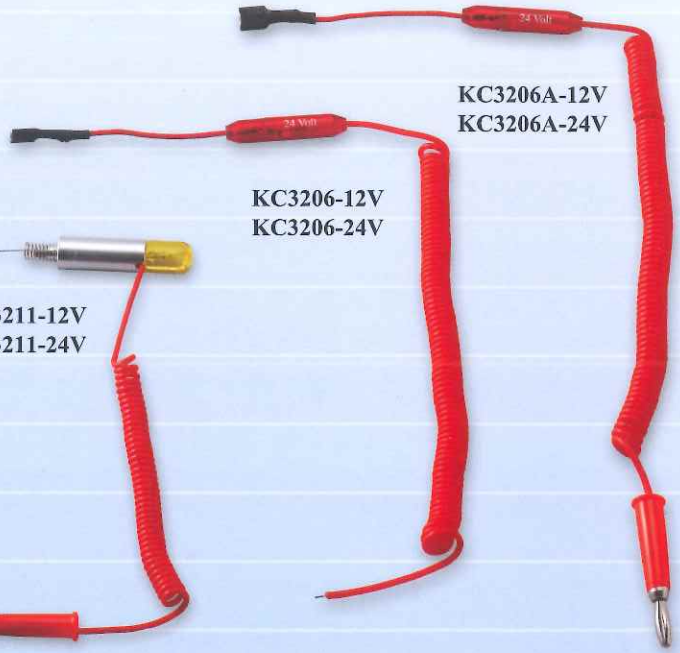

KC3206-12V  
KC3206-24V

KC3206A-12V  
KC3206A-24V



KC3211-12V  
KC3211-24V



KC3215A

KC3218



KC3207



KC3207S



KC3208S



KC3208



KC3207C  
(Hole:6.5mm)



KC3209  
(Hole:6.5mm)



KC3212

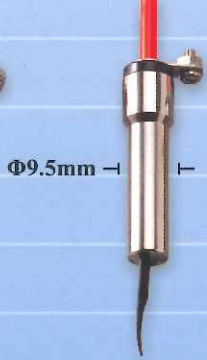

KC3201



KC3202

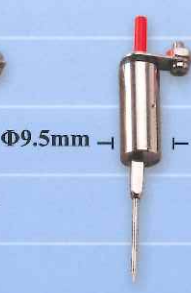

KC3203

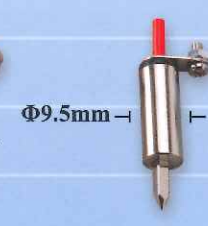

KC3205



KC3201B  
(Hole:10mm)



KC3201A  
(Hole:10mm)

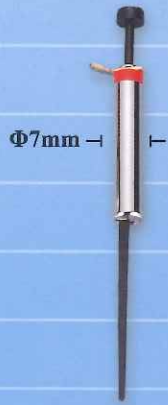

KC3201-1

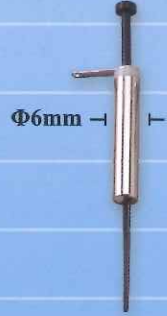

KC3201-1A

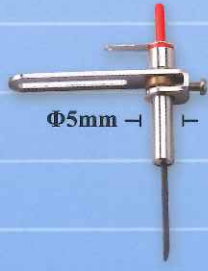

KC3210

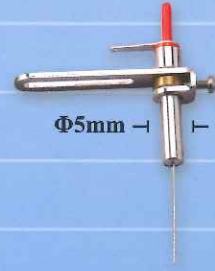

KC3210-B

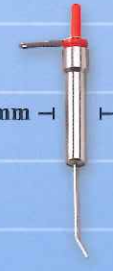

KC3210-D

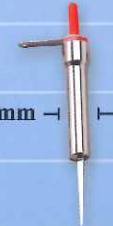

KC3210-E

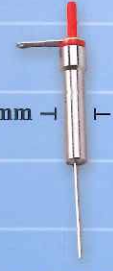

KC3210-N



# TAPE STRETCHERS



J102M



J102MA



J103M (First)  
J103M-H (Second)



J103MA (First)  
J103MA-H (Second)



J103A (First)  
J103A-H (Second)  
J103A-T (Third)



J113M-S (Single)  
J113M-D (Double)



J112M-S (Single)  
J112M-D (Double)



J5401 (H:25mm)  
J5402 (H:55mm)  
J5403 (H:85mm)



J112M-D1

# QUALITY WHEELS

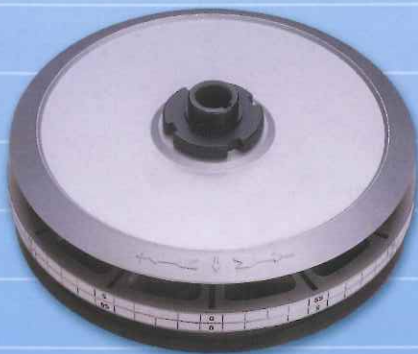

DOUBLE:  
KC5301-1 (180mm)  
KC5302-1 (210mm)  
KC5302C-1 (250mm)



SINGLE:  
KC5301 (180mm)  
KC5302 (210mm)  
KC5302C (250mm)



KC5301-SEG  
(only used with E-Hwa Quality Wheels)

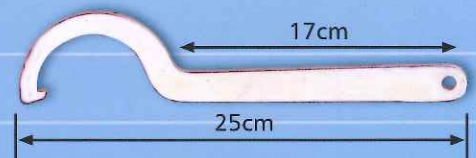

J5306





KC1310B



J601

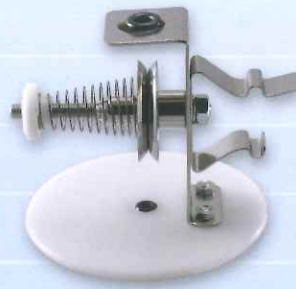

J601A

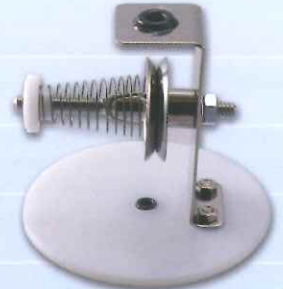

J601B



KC1302B



KC1302



J606



KC1308 (L:7mm)  
KC1308-L (L:14mm)



KC1302D



KC1309B-S



KC1309-1 (L:8mm)  
KC1309-1-L (L:12.5mm)



KC1309

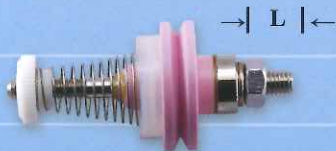

KC1313B (L:24mm)  
KC1313B-A (L:12.7mm)



KC1304 (L:14mm)

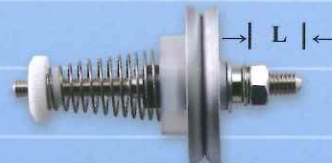

KC1310A (L:14mm)



KC1318 (L:14mm)

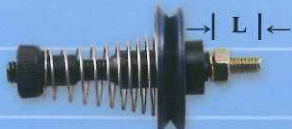

KC1306 (L:11.5mm)

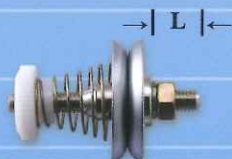

KC1316A (L:10mm)



J2508B



KI-05-332-1



# TENSIONERS & STOP MOTIONS



KC1092

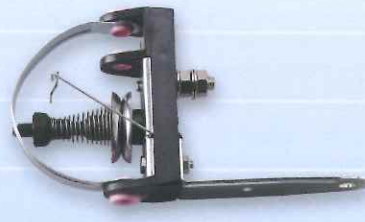

KC1085A



KC1085B



KC1317

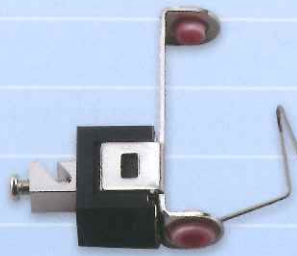

KC1085C

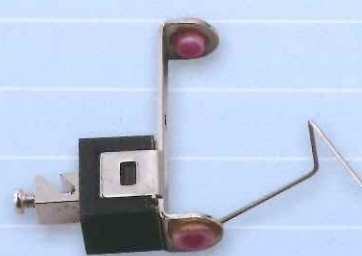

KC1085D



KC1085



KI571



KI572



KI573



TK-27-P



TK-27-R



TK-27-T



TK-27-T1



CI-PS002



CTA-CAP

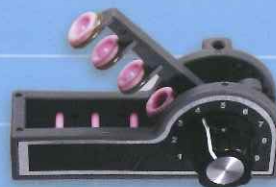

KI112



KI113D



## CYLINDERS

Type: Variety of Single and Double Knit cylinders

Diameter: from 4" up to 60"

Gauge: from E6 up to E42

Material: high quality S48CLN steel from Japan

Quality: superb equal hardness on the verge



SINGLE JERSEY CYLINDER



DOUBLE JERSEY CYLINDER

## GAUGE & DIAL INDICATORS



OI023S



OI023

## WORM WHEELS & GEARS

Please send inquiry with Samples



## CREEL TUBE STANDS



CTR-8F  
CTR-9F



ALUMINUM TUBE:  
CTA2-8F-ALUM  
CTA2-9F-ALUM



ALUMINUM TUBE:  
CTA1-8F-ALUM  
CTA1-9F-ALUM

PVC TUBE:  
CTA1-8F-PLST  
CTA1-9F-PLST



# TUBE PARTS & ACCESSORIES



CTA-EBA-0808 (8×8mm)  
CTA-EBA-0810 (8×10mm)  
CTA-EBA-1010 (10×10mm)  
CTA-EBA-1012 (10×12mm)



CTA-CLIP-8  
CTA-CLIP-10  
CTA-CLIP-12



CTA-HOLD-8P  
CTA-HOLD-9.5P  
CTA-HOLD-10P



CTA-HOLD-8S  
CTA-HOLD-10S



TK-31



TK-40



TK-38-8



TK-26D



C-J607R  
C-J607L



OC310A

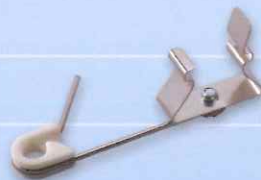

CI-ST1280A

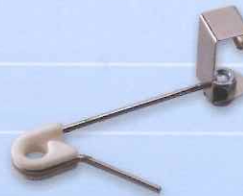

CI-ST1280A-1



J3212



J3212-S

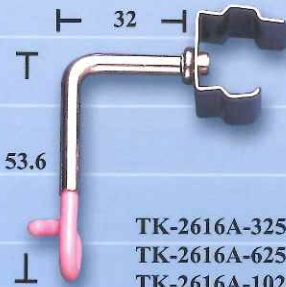

TK-2616A-325 (3×25 Clip)  
TK-2616A-625 (6×25 Clip)  
TK-2616A-1020 (10×20 Clip)

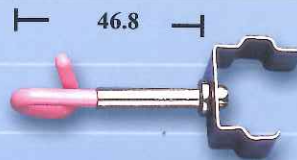

TK-26BA-325 (3×25 Clip)  
TK-26BA-625 (6×25 Clip)  
TK-26BA-1020 (10×20 Clip)



TK-26A-325 (3×25 Clip)  
TK-26A-625 (6×25 Clip)  
TK-26A-1020 (10×20 Clip)

# TENSION METERS



1~5 cN  
2~12 cN  
2~20 cN  
3~30 cN  
5~50 cN  
10~100 cN

OI016  
(GERMAN BRAND)



YTM-25  
(GERMAN BRAND)



OI016Z  
(SWISS BRAND)



## FANS



FAN-2 MIDDLE 2-HEAD FAN 220V  
 FAN-2-P1 8" FAN BLADE ONLY  
 FAN-2-M FAN MOTOR ONLY  
 FAN-2-M1 MAIN MOTOR ONLY  
 FAN-2-MP FAN MOTOR WITH BLADE



FAN-3 TOP 3-HEAD FAN 220V  
 FAN-3-P1 11" FAN BLADE ONLY  
 FAN-3-M FAN MOTOR ONLY  
 FAN-3-M1 MAIN MOTOR ONLY  
 FAN-3-MP FAN MOTOR WITH BLADE

## CLEANING GUN



JC-77A (NON-ADJUSTABLE)  
 JC-77B (ADJUSTABLE)  
 (110V or 220V)



JC-77-20A (NON-ADJUSTABLE)  
 JC-77-20B (ADJUSTABLE)

## OIL SPRAYER



OIL TUBE:  
 JC-88-03A (5×2.5mm)  
 JC-88-03 (4.5×2mm)

JC-88 (LUBRICATOR 24V)

## AIR GUNS & AIR HOSES



OI564



OI554



OI555 (6/9/12/15m)



# SCISSORS & BLADES



S-110



J2000



OC307



S-108  
S-108A (ROUNDED TIP)



J2000-B (L:84.5mm)  
J2000-BS (L:44mm)



OC307-S



OC307-A



OC303-1A



OC308



S-105



OC303-1



OC303

# MINI CLOTH CUTTER



OI027-110V  
OI027-220V

# MAGNIFIER



HB-1 1"  
HB-2 1/2"  
HB-3 1" (W/ INDICATOR)



HB-1A 1"  
(W/ LIGHT)

# SAMPLE CUTTER



OI021 (Cutter)  
(Φ11.28cm)

OI021-B (Blade)  
OI021-P (PU Board)

# COMPACT BALANCE



OI022D-110V  
OI022D-220V  
(300g×0.01g)



## CLOTH WINDER

When sending inquiries, please advise,

1. Roller Length
2. Turning Direction: Clockwise / Counterclockwise
3. M/C Type: Single Jersey / Interlock
4. Revolving Diameter



Clockwise



Counterclockwise

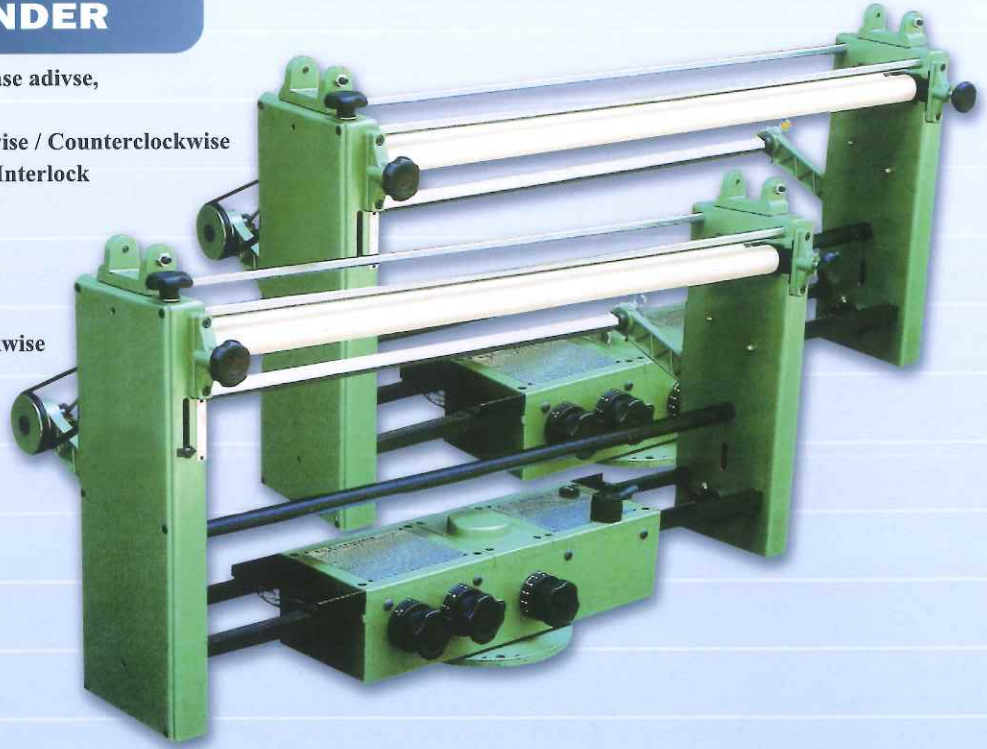

PART NO.	KC598-40	KC598-42	KC598-44	KC598-47	KC598-51	KC598-55	KC598-57
Cylinder Dia.(in)	26	28	30	32	34	36	38
Roller Length (in)	40	42	44	47	51	55	57
Net Weight (kg)	128	132	137	144	152	160	171

## FABRIC SPREADERS



(For Single Jersey M/C)

PART NO.	KC599-376169-1	KC599-376169-2	KC599-376169-3	KC599-376169-4	KC599-376169-5	KC599-376169-6	KC599-376169-S1	KC599-376169-S2	KC599-376169-S3	KC599-376169-S4	KC599-376169-S6
M/C SIZE	11"-14"	15"-17"	18"-23"	24"-30"	32"-38"	32"-38"	11"-14"	15"-17"	18"-23"	24"-30"	32"-38"
ADJUSTABLE WIDTH	12"-16"	16"-22"	22"-28"	26"-39"	38"-53"	38"-53"	12"-16"	16"-22"	22"-28"	26"-39"	38"-53"
SPREADER HEIGHT	9"	9"	9"	9"	13"	9"	7 1/2"	7 1/2"	7 1/2"	7 1/2"	7 1/2"



# DROP WIRE STOP MOTIONS

Pls Send the Inquiry with Creel No.,  
Yarn Denier, & Direction (Right / Left Side)



ER-3A

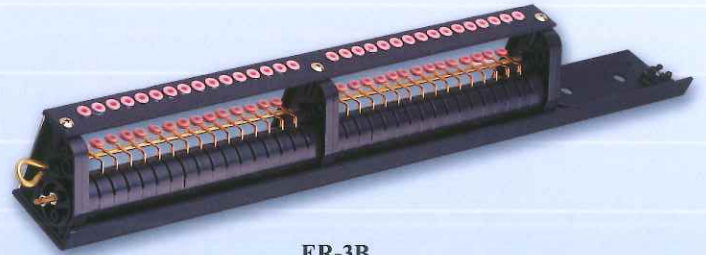

ER-3B

# OIL TENSIONS

Pls Send the Inquiry with Yarn Denier & Direction.



ER-2 WITH WASHER



ER-2-01 WITHOUT WASHER



ER-2-04 WITH WASHER



ER-5



# CERAMIC EYELETS

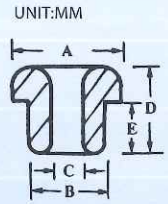
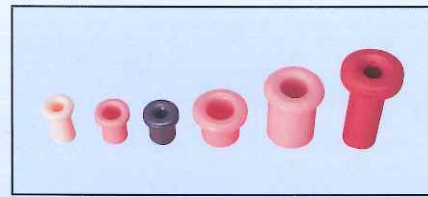
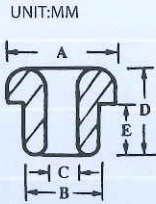

Part Number	A	B	C	D	E
G1510A.09	2.0	1.5	0.9	12.0	10.5
G1805A.10	2.0	1.8	1.0	6.4	5.2
G2102D.10	3.1	2.0	1.0	3.0	2.0
G2104C.10	3.1	2.0	1.0	5.0	4.0
G2503D.15	3.8	2.5	1.5	4.0	3.0
G2503A.18	3.3	2.5	1.8	4.0	3.0
G2504A.15	3.8	2.5	1.5	5.0	4.0
G2504A.17	3.8	2.5	1.7	5.3	4.0
G2505A.15	3.8	2.5	1.5	6.8	5.5
G2507A.15	3.8	2.5	1.5	8.3	7.0
G2513A.16	4.0	2.5	1.6	15.0	13.5
G2514A.17	3.8	2.5	1.7	15.2	14.2
G2803A.10	4.0	2.8	1.0	4.2	3.0
G2803A.12	4.8	2.9	1.2	4.2	3.0
G2902A.15	4.8	2.9	1.5	3.0	2.0
G2903A.15	4.8	2.9	1.5	4.0	3.0
G3001A.17	4.2	3.0	1.7	2.0	1.2
G3002A.17	4.2	3.0	1.7	3.0	2.0
G3003A.20	4.2	3.0	2.0	3.8	3.0
G3004A.20	4.2	3.0	2.0	4.8	4.0
G2905A.15	4.8	3.0	1.5	6.5	5.0
G3302A.20	4.5	3.3	2.0	3.5	2.5
G3705T.20	4.7	3.7	2.0	6.6	5.0
G3721A.26	5.9	3.7	2.5	23.0	22.0
G3903A.15	5.5	3.8	1.5	4.5	3.0
G3915A.19	5.5	3.8	1.9	3.0	1.5
G3904A.19	5.5	3.8	1.9	5.2	4.0
G3903W.20	5.8	3.8	2.0	4.5	2.5
G3803A.15	7.0	3.8	1.5	4.2	2.7
G3803C.20	7.0	3.8	2.0	4.0	2.5
G3903A.19	5.5	3.9	1.9	4.3	3.0
G4025A.22	5.5	4.0	2.2	4.2	2.5
G4003A.25	5.0	4.0	2.5	4.0	3.0
G4004A.25	5.0	4.0	2.5	5.0	4.0
G4203A.25	5.8	4.2	2.5	4.3	3.0
G4205C.25	5.8	4.2	2.5	5.7	4.7
G4306A.20	5.9	4.3	2.0	7.1	5.9
G4308A.20	5.9	4.3	2.0	9.2	7.9
G4403A.20	5.9	4.4	2.0	5.0	3.5
G4303C.OR	6.6	4.4	1.9	3.8	2.8
G4807W.33	6.5	4.6	3.3	8.0	6.4
G4704A.25	6.0	4.7	2.5	5.0	4.0
G4802A.33	6.5	4.8	3.3	3.5	2.0
G4803A.33	6.5	4.8	3.3	4.5	3.0
G4804A.33	6.5	4.8	3.3	5.6	4.0
G4805A.33	6.5	4.8	3.3	6.5	5.0
G4806A.33	6.5	4.8	3.3	7.0	5.5
G5025A.20	6.6	5.0	2.0	3.5	2.5
G5003W.20	6.6	5.0	2.0	4.6	3.0
G5005C.20	6.6	5.0	2.0	7.0	5.5

Part Number	A	B	C	D	E
G5006A.20	6.6	5.0	2.0	8.0	6.5
G5104A.33	6.8	5.0	3.3	5.5	4.0
G5103A.33	6.8	5.1	3.3	4.0	2.8
G5204C.33	6.8	5.1	3.3	5.5	4.0
G5205W.33	6.8	5.1	3.3	7.0	5.0
G5203A.23	7.1	5.2	2.3	4.8	3.2
G5304A.33	6.8	5.3	3.3	5.2	4.0
G5306C.33	6.8	5.3	3.3	7.5	6.0
G5705A.31	7.9	5.6	3.1	6.4	5.1
G5804O.30	7.8	5.8	2.9	6.0	4.0
G5763A.33	7.8	5.8	3.3	8.0	6.3
G5902A.35	7.8	5.9	3.4	3.5	2.0
G5803W.31	8.3	5.9	3.0	4.8	3.0
G5903W.35	7.8	5.9	3.4	4.8	3.0
G5903C.35	7.8	5.9	3.4	4.8	3.0
G5904A.35	7.8	5.9	3.4	6.0	4.0
G5904C.35	7.8	5.9	3.4	6.0	4.0
G5905C.35	7.8	5.9	3.4	7.0	5.0
G5906C.35	7.8	5.9	3.4	8.0	6.0
G6007C.35	7.8	5.9	3.4	8.0	6.4
G5903W.31	8.3	5.9	3.0	4.8	3.0
G6002C.32	7.6	6.0	3.2	3.6	2.0
G6005A.35	7.8	6.0	3.4	6.5	5.0
G6016W.35	8.2	6.0	3.5	17.7	16.0
G6204A.35	8.1	6.1	3.5	6.0	4.2
G6107C.40	8.6	6.1	4.1	8.0	6.5
G6108A.40	10.2	6.1	4.1	9.8	7.8
G6235S.32	7.8	6.2	3.2	4.5	3.5
G6105A.30	8.0	6.2	3.0	7.0	5.0
G6202W.35	8.1	6.2	3.5	2.8	1.8
G6205A.35	8.1	6.2	3.5	7.0	5.0
G6303W.35	8.0	6.3	3.5	3.5	2.5
G6304A.35	8.0	6.3	3.5	4.5	3.5
G6307A.40	8.4	6.3	4.0	8.1	6.6
G6405A.40	8.7	6.3	4.0	6.5	5.0
G6409C.29	10.6	6.3	2.9	10.4	8.4
G6403T.OR	8.1	6.4	3.3	5.0	3.5
G6404C.40	8.7	6.4	4.0	4.6	3.3
G6407A.40	8.7	6.4	4.0	8.4	6.7
G6602B.00	8.1	6.6	4.9	2.1	1.4
G6603A.38	8.7	6.6	3.8	5.0	3.0
G6504A.38	8.7	6.6	3.8	6.0	4.0
G6606C.38	8.7	6.6	3.8	7.5	6.0
G6906A.45	9.1	6.9	4.5	7.8	5.8
G7004T.45	9.2	6.9	4.5	5.7	4.0
G7010A.40	10.1	6.9	4.0	11.8	10.0
G7003A.28	9.0	7.0	2.8	5.0	3.2
G7005A.40	9.0	7.0	4.0	7.0	5.2
G7005A.45	9.2	7.0	4.5	7.0	5.3
G7203C.48	9.9	7.1	4.8	5.0	3.1



# CERAMIC EYELETS

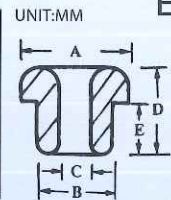
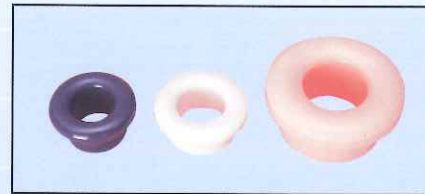
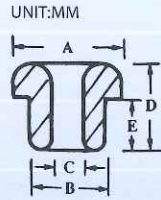
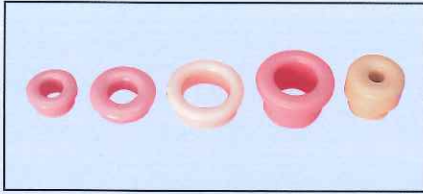

Part Number	A	B	C	D	E
G7205A.48	9.9	7.1	4.8	6.7	5.0
G7206A.48	9.9	7.1	4.8	7.6	6.0
G7307A.35	8.8	7.2	3.4	8.3	7.0
G7305C.35	8.8	7.3	3.4	6.7	4.9
G7309A.35	8.8	7.3	3.4	11.0	9.0
G7306C.39	9.5	7.3	3.9	7.4	5.5
G7305O.39	9.5	7.3	3.9	7.5	5.0
G7307A.39	9.5	7.3	3.9	9.0	7.0
G7406D.40	9.5	7.3	3.9	8.0	6.0
G7405T.32	9.7	7.4	3.2	7.0	5.2
G7505C.37	9.6	7.5	3.7	7.2	5.0
G7605A.44	9.7	7.5	4.4	7.0	5.0
G7609C.44	9.7	7.5	4.4	11.0	9.0
G7707A.48	10.7	7.5	4.8	8.8	7.0
G7808A.54	10.0	7.5	5.4	9.5	8.0
G7602W.50	8.6	7.6	5.0	3.1	2.0
G7704W.48	10.6	7.6	4.8	5.0	4.0
G7705A.48	10.7	7.6	4.8	6.5	4.5
G7608A.55	9.6	7.7	5.5	10.0	8.0
G7803D.60	9.6	7.8	6.0	4.0	3.0
G7905A.40	10.0	7.9	4.0	7.0	5.0
G7905A.50	10.0	7.9	5.0	7.2	5.0
G7904A.40	10.0	8.0	4.1	6.3	4.4
G7008C.40	10.1	8.0	4.0	9.8	8.0
G7907A.40	10.0	8.0	4.1	8.3	6.4
G8205W.46	10.2	8.1	4.6	7.2	5.0
G8202C.00	9.4	8.2	4.3	3.0	2.0
G8708A.49	10.7	8.4	4.8	10.0	8.0
G9005T.30	11.2	8.4	2.8	11.0	4.5
G8706C.49	10.7	8.6	4.8	8.0	6.0
G8908A.48	10.6	8.8	4.8	10.3	8.3
G8811A.53	12.9	8.8	5.3	13.5	11.2
G8814C.53	12.9	8.8	5.3	16.4	14.0
G8911A.48	10.6	8.9	4.8	13.3	11.3
G8913A.63	12.7	8.9	6.3	15.2	12.7
G9005W.62	12.7	9.0	6.2	7.5	5.0
G8905T.40	13.0	9.0	4.0	7.0	5.0
G9205A.53	11.6	9.1	5.3	7.0	5.0
G9207C.53	11.6	9.1	5.3	8.7	6.9
G9408A.62	12.0	9.4	6.2	10.5	8.4
G9509C.66	13.0	9.5	6.6	10.5	9.0
G9502T.66	13.2	9.5	6.6	7.8	1.8
G9506A.47	12.7	9.5	4.7	9.5	6.3
G9507A.62	12.0	9.6	6.2	9.0	7.0
G9608C.62	12.0	9.6	6.2	10.5	8.4
G9822A.53	14.7	9.8	5.3	25.0	22.0
G1006W.50	11.8	9.9	4.9	9.0	5.5
G9907A.OR	11.9	9.9	6.1	8.5	7.0
G1004A.70	12.1	9.9	7.0	6.0	4.0
G1009A.70	12.1	9.9	7.0	11.0	9.0

Part Number	A	B	C	D	E
G9813A.63	13.5	9.9	6.3	16.5	13.0
G1007T.50	12.0	10.0	4.9	8.5	6.5
G1011A.50	12.0	10.0	5.0	15.0	11.0
G1011A.60	12.0	10.0	6.0	15.0	11.0
G1065W.65	14.0	10.0	6.5	9.5	6.5
G1004W.81	12.8	10.4	7.9	7.9	4.0
G1102N.00	11.9	10.8	8.5	2.5	1.7
G1109W.65	14.0	10.9	6.5	12.0	9.6
G1119C.77	14.0	11.0	7.7	11.0	8.5
G1135A.70	14.0	11.3	7.0	7.0	5.0
G1188C.78	14.9	11.7	8.3	10.0	7.5
G1197A.78	15.4	11.9	7.6	10.2	7.2
G1204A.78	15.4	11.9	7.6	7.0	4.0
G1265T.78	15.4	11.9	7.6	8.9	6.5
G1265T.68	15.0	12.1	6.6	8.9	6.5
G1254A.87	15.9	12.5	8.7	7.0	4.0
G1257A.87	15.7	12.5	8.7	10.2	7.2
G1260A.87	15.9	12.5	8.7	14.0	11.0
G1274A.16	15.9	12.7	8.7	7.2	4.0
G1287C.18	18.0	12.8	8.7	10.2	7.2
G1288A.18	18.0	12.8	8.7	11.0	8.0
G1281W.18	18.0	12.8	8.7	14.0	11.0
G1556A.10	19.5	15.3	9.7	8.4	5.4
G1550A.10	19.5	15.3	9.7	13.6	10.0
G1810O.12	22.3	18.2	12.1	13.5	10.0
G2190A.16	28.3	22.0	16.0	14.0	10.0
G2596A.20	31.5	25.6	19.8	8.0	6.0
G3020A.20	35.0	29.8	20.2	25.0	20.0
G4086A.32	47.3	41.0	32.8	10.8	6.8

# DOUBLE FLANGED EYELETS

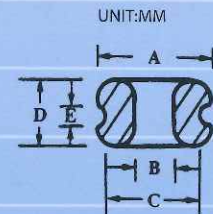

Part Number	A	B	C	D	E
W2543A.00	5.4	2.4	4.4	3.2	1.0
W2693A.00	6.9	3.0	6.0	3.0	1.0
W2804C.20	8.2	3.2	6.0	4.3	2.0
W2805A.00	8.0	3.2	6.1	4.8	1.7
W2916C.00	9.1	3.3	7.4	5.8	2.9
W2836A.00	8.3	3.6	5.6	6.5	1.6
W2105A.70	10.4	4.9	7.0	5.3	2.5
W2137W.62	13.0	6.2	11.0	7.0	3.5
W2132S.00	13.0	6.5	10.0	11.8	6.3
W2247A.00	24.1	14.4	20.0	7.0	4.0



## GROOVED EYELETS

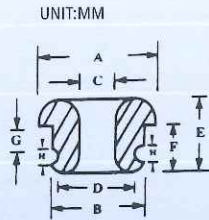

Part Number	A	B	C	D	E	F	G	H
W0581C.30	8.2	5.8	3.0	4.5	6.8	5.0	1.2	1.1
W0582A.10	8.3	5.9	3.0	5.1	6.5	4.9	2.2	0.9
W0582C.14	8.3	5.9	3.0	4.9	6.6	4.9	2.2	1.4
W0602W.32	7.6	6.0	3.2	5.2	5.1	3.8	1.4	1.0
W0622C.30	8.0	6.1	3.0	5.1	5.9	4.0	1.5	1.0
W0642C.30	8.0	6.3	3.0	5.2	5.8	4.0	1.5	1.0
W0652A.38	8.6	6.5	3.7	5.2	5.7	4.1	1.2	0.8
W0746A.35	8.8	7.3	3.4	5.9	10.6	8.6	6.0	1.2
W0753A.44	9.7	7.5	4.5	6.8	7.4	5.5	3.5	1.5
W0784A.40	9.3	7.7	4.0	6.6	8.2	6.7	3.5	1.1
W0794A.35	9.4	7.8	3.6	6.8	8.1	6.4	3.8	1.0
W0795C.40	9.9	7.8	4.3	7.0	10.5	8.3	4.8	1.0
W0804C.15	9.6	7.9	1.6	7.0	8.5	6.5	3.7	1.0
W0804A.36	9.6	7.9	3.8	7.1	8.5	6.7	3.7	1.0
W0125C.78	15.1	11.0	8.3	10.4	11.5	8.6	5.0	1.0
W0126T.64A	15.2	11.1	6.1	10.0	14.2	11.1	6.4	1.4

## SLOTTED EYELETS

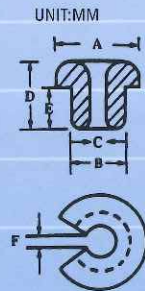
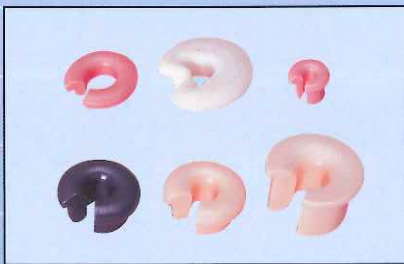

Part Number	A	B	C	D	E	F
W1353T.00	5.3	3.5	2.0	4.2	3.0	0.8(60°)
W1403A.00	5.2	3.8	1.6	4.2	3.1	0.8(50°)
W1682A.00	9.2	6.8	4.0	3.2	1.5	1.7(45°)
W1733C.00	9.9	7.3	3.2	4.5	2.6	1.5(60°)
W1783O.00	10.3	7.8	3.2	5.5	3.5	1.0(60°)
W1803C.00	10.4	8.0	3.2	5.5	3.5	1.4(60°)
W1967A.00	12.6	9.5	4.7	9.8	7.1	3.3
W1104C.00	12.0	10.0	4.0	5.5	3.6	2.0(45°)
W1107O.00	12.0	10.0	4.0	7.9	6.9	2.1(45°)

## PIGTAIL GUIDES

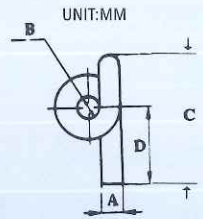
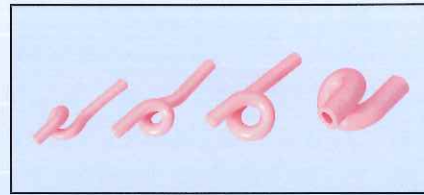

Part Number	A	B	C	D
B3027A-L	2.9	3.0	27.0	18.0
B3027A-R	2.9	3.0	27.0	18.0
B3232A-L	3.2	3.0	32.0	22.0
B3232A-R	3.2	3.0	32.0	22.0
B4027A-L	3.7	5.0	27.0	18.0
B4032A-L	3.9	5.0	32.0	22.0
B4032A-R	3.9	5.0	32.0	22.0
B4036A-L	4.0	4.0	36.0	25.0
B4036A-R	4.0	4.0	36.0	25.0
B5052A-L	4.8	7.0	52.0	39.7
B5017A-L3	5.0	3.0	17.0	10.0
B5017A-R3	5.0	3.0	17.0	10.0
B6026A-L3	6.0	4.5	26.0	16.0
B6026A-R3	6.0	4.5	26.0	16.0

## CERAMIC POSTS

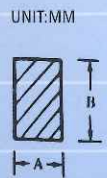
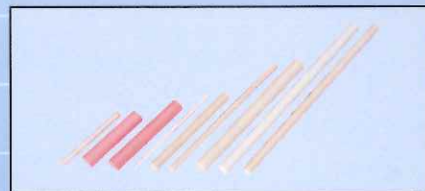

Part Number	A	B
D1520A.00	1.5	20.0
D2017A.00	2.0	17.0
D2417A.00	2.4	17.0
D3011A.00	3.0	11.0
D3030A.00	3.0	30.0
D3035A.00	3.0	35.0
D5020A.00	5.0	20.0
D5025A.00	5.0	25.0
D5030A.00	5.0	30.0
D5050A.00	5.0	50.0
D8045A.00	8.0	45.0
D8060O.00	8.0	60.0

## ANGLED TUBES



ALL SIZES CAN BE MADE UPON REQUEST.



# CERAMIC TUBES

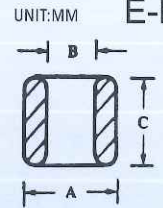
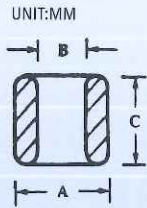
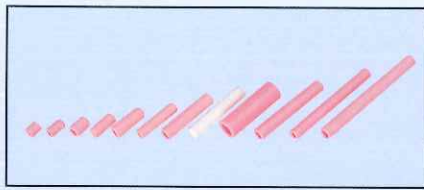

Part Number	A	B	C
E1510A.09	1.4	0.9	10.5
E2011A.10	1.8	0.9	11.0
E1865A.10	1.9	1.0	6.5
E1911A.09	1.9	1.0	11.0
E1914A.10	1.9	1.0	14.0
E2006A.10	2.0	1.0	6.0
E2007A.10	2.0	1.0	7.0
E2008A.10	2.0	1.0	8.0
E2010A.10	2.0	1.0	10.0
E2014A.10	2.0	1.0	13.8
E2016A.10	2.0	1.0	16.0
E2020A.11	2.0	1.0	20.0
E2025A.10	2.0	1.0	25.4
E2310A.13	2.3	1.3	10.0
E2314A.14	2.3	1.4	14.0
E2503A.16	2.4	1.6	3.0
E2504A.16	2.4	1.6	4.0
E2505A.16	2.4	1.6	5.0
E2506A.16	2.4	1.6	6.0
E2507A.16	2.4	1.6	7.0
E2508A.16	2.4	1.6	8.0
E2509A.16	2.4	1.6	9.0
E2512A.16	2.4	1.6	12.0
E2525A.16	2.4	1.5	25.0
E2565A.15	2.5	1.5	6.5
E2510A.16	2.5	1.4	10.0
E2514A.16	2.5	1.6	14.0
E2515A.16	2.5	1.6	15.0
E3003A.22	2.9	2.0	3.0
E3004A.22	2.9	2.2	4.0
E3005A.22	2.9	1.9	5.0
E3008A.20	2.9	2.0	8.0
E3010A.20	2.9	1.9	10.0
E3012A.20	3.0	2.0	12.0
E3014A.17	2.9	1.7	14.0
E3014A.21	3.0	2.1	14.0
E3020A.20	3.0	2.0	20.0
E3025A.21	3.0	2.1	25.0
E3030A.21	3.0	2.0	30.0
E3016A.20	3.0	2.0	16.0
E3505A.26	3.5	2.6	5.0
E3507A.26	3.5	2.5	7.0
E3807A.26	3.8	2.6	7.0

Part Number	A	B	C
E4006A.27	4.0	2.7	6.0
E4010A.26	4.0	2.5	10.5
E4020A.27	4.0	2.6	20.0
E4406A.32	4.4	3.2	6.0
E4840A.33	4.8	3.2	40.0
E5008A.36	5.0	3.6	8.3
E5015A.30	5.0	3.0	15.0
E5020A.37	5.0	3.7	20.0
E5040A.33	5.0	3.3	40.0
E6006A.32	6.4	3.2	6.0
E6013A.43	5.9	4.2	13.0
E6025A.35	6.0	3.5	25.0
E7045A.45	7.0	4.5	45.0
E8020A.50	8.0	5.0	20.0
E8010A.54	8.0	5.4	10.0
E8010S.62	8.0	6.2	10.0
E8020A.55	8.0	5.5	20.0
E8045A.53	8.0	5.3	45.0



Part Number	A	B	C
H5005A.30	5.0	3.0	5.0
H6006A.30	5.8	3.2	6.0
H8020C.45	7.3	4.2	15.0
H8015A.52	7.8	5.0	15.0
H8310C.55	8.3	5.5	10.0
H9018D.40	9.0	4.0	17.7
H9515D.55	9.5	5.5	15.1
H1020A.60	9.8	6.0	20.0
H9822A.55	9.8	5.5	22.2
H9828A.60	9.8	6.0	28.0
H1008C.70	9.9	7.0	8.0
H1020W.55	10.2	5.5	20.0
H1020C60A	10.4	6.0	20.0
H1323A.83	12.3	8.4	23.0
H1320C.83	12.8	8.4	20.0
H1332A.64	13.0	6.3	32.0
H1510A.10	15.3	9.8	10.3



# ROLLERS WITH BEARING

Part Number	A	B	C	D	E
EJ5317320	20.0	15.0	3.0	4.0	3.0
EJ5322028	28.5	20.0	4.0	6.0	4.0
EJ5317330	30.0	15.0	3.0	10.0	3.0
EJ5322440	40.0	20.0	4.0	15.0	4.0
EJ5335645	45.0	30.0	6.0	10.0	6.0
EJ5336651	51.0	30.0	6.0	12.0	6.0
EJ5335660	60.0	30.0	6.0	20.0	6.0
EJ5344660	60.0	40.0	8.0	14.0	7.0
EJ5344680	80.0	40.0	8.0	25.0	7.0
EJ5360979	80.0	50.0	10.0	15.0	9.0
EJ5360910	100.0	50.0	10.0	30.0	9.0
EJ5310513	130.0	100.0	10.0	15.0	9.0
EC8030D20	8.0	6.0	2.0	3.4	2.4
EC1040D20	10.0	8.0	2.0	4.0	3.0
EC1135D20	10.5	7.0	2.0	3.5	2.3
EC1460D30	14.0	10.0	3.0	6.0	3.0
EC1770D40	16.5	13.5	4.0	7.0	4.0
EC2010D40	20.0	14.0	4.0	10.0	4.0
EC2308A40	23.0	15.0	4.0	8.0	5.0
EC3024D50	30.0	20.0	5.0	24.0	10.0
EC3010D80	30.0	22.0	8.0	10.0	5.0
EC4012D80	40.0	24.0	8.0	12.0	5.0
EC4024D80	40.0	27.0	8.0	24.0	14.5

## EJ-PLASTIC

- (1) Both V and U groove are available.
- (2) Both polished and without polished are available.

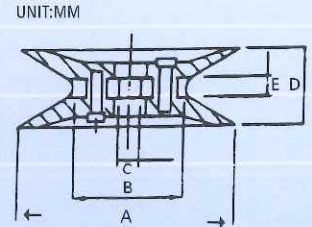

## EC-CERAMIC

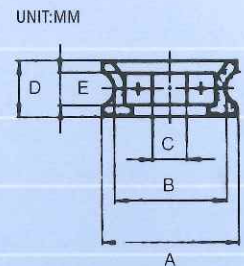

# CERAMIC DISCS & METAL DISCS

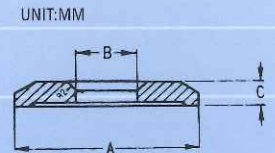

## CERAMIC DISCS

## METAL DISCS

Part Number	A	B	C	WT(g)	Part Number	A	B	C	WT(g)	CHROMED
W6213A.15	20.6	5.2	2.1	1.5	DCM22786	22.8	8.5	3.0		
W6214A.15	20.6	6.8	2.1	1.5	DCM23261	23.0	6.1	2.4		
W6214A.25	20.6	6.8	3.4	2.3	DCM23112	23.4	11.2	2.0	1.2	
W6223W.00	22.0	5.3	3.6	2.2	DCM24256	24.2	5.6	2.5	1.5	
W6243A.20	24.0	8.2	3.0	1.4	DCM26383	26.3	8.3	3.1	1.8	SHINING
W6243A.30	24.0	8.2	3.0	2.3	DCM28388	28.3	8.8	2.7	2.2	
W6253A.30	24.7	10.2	3.5	3.0	DCM30265	30.0	6.5	2.7		
W6253C.50	24.7	10.2	5.1	5.0	DCM30311	30.3	11.0	4.0	3.2	SHINING
W6253W.30	24.7	10.2	3.5	3.0	DCM30402A+P	30.4	2.9	3.5	1.8	DULL
W6263A.30	25.4	8.6	3.0	3.0	DCM35410A	35.3	10.0	4.0		DULL
W6263C.35	26.0	8.5	2.8	4.4	DCM35510A	35.5	11.0	3.6	5.5	SHINING
W6273A.00	26.5	10.6	3.0	3.0	DCM35510	35.5	11.0	5.8	5.4	DULL
W6273A.13	26.5	13.0	3.0	3.0	DCM35511	35.5	10.4	3.8	3.0	DULL
W6293A.40	29.5	10.9	4.0	5.4	DCM35710A	35.7	10.3	6.1	6.5	SHINING
W6365A.00	36.4	10.5	3.7	7.5	DCM35710A-4	35.7	10.3	6.0	4.5	SHINING
F4048T.00	35.0	15.0	4.0		DCM35710A-5	35.7	10.3	5.7	5.6	SHINING
W6365A.11	36.4	11.7	3.6	12.5	DCM36510A	36.0	10.2	5.5	6.0	DULL
					DCM380107	38.0	10.7	4.0	6.8	DULL



# TABLE OF CONTENTS

1 2	CAMS		13	TENSIONERS	
3 4	ZIRCONIA YARN CARRIERS		14	TENSIONERS STOP MOTIONS	
5	YARN CARRIERS		15	CYLINDERS GAUGE & DIAL INDICATORS WORM WHEELS & GEARS CREEL TUBE STANDS	
6	LYCRA ROLLERS BRACKETS YARN GUIDES		16	TUBE PARTS & ACCESSORIES TENSION METERS	
7	POSITIVE FEEDERS WIRES INTERMITTENT AUTOMATIC STORAGE FEEDERS		17	FANS OIL SPRAYER CLEANING GUN AIR GUNS AIR HOSES	
8	MAGNETIC DISCS KNOT CATCHERS		18	SCISSORS & BLADES MINI CLOTH CUTTER MAGNIFIER COMPACT BALANCE SAMPLE CUTTER	
9	LYCRA FEEDERS POSITIVE FEEDING DEVICE TAPE VULCANIZERS BELTS		19	CLOTH WINDER FABRIC SPREADERS	
10	LYCRA / YARN STOP MOTIONS BULBS		20	DROP WIRE STOP MOTIONS OIL TENSIONS	
11	NEEDLE DETECTORS		21 22 23	CERAMIC GUIDES & METAL DISCS	
12	TAPE STRETCHERS QUALITY WHEELS		24 25		





## WELCOME NEW DESIGN

- ZIRCONIA YARN CARRIERS
- STEEL YARN CARRIERS
- CAMS
- CYLINDERS
- TENSIONS
- CERAMIC YARN GUIDES
- DYE SPRINGS
- SINKERS
- ALL KINDS OF CNC WORK



E-HWA

邑榉有限公司

E-HWA COMPANY LTD.

P.O.BOX 366 SAN CHUNG DIST.  
NEW TAIPEI CITY, 24199, TAIWAN

TEL:886-2-2999-3382(REP.)

FAX:886-2-2999-1921

<http://www.e-hwa.com.tw>

e-mail:sales@e-hwa.com.tw

ehwa@ms15.hinet.net