

**TAILOR
MADE
BENEFIT**

m a t e x
ECO APPLICATOR

Matex Eco Applicator

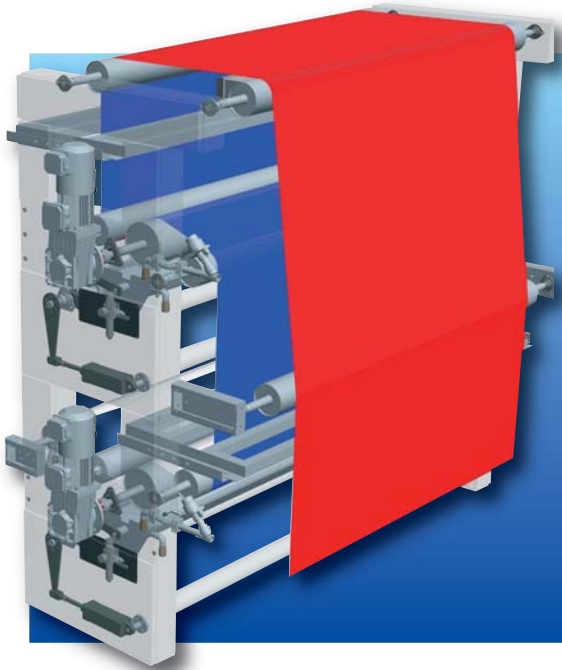

- Minimum liquor application device with driven liquor rollers. The alternative to padding.
For energy-conscious and cost-cutting drying. Reduced liquor content for lower remaining liquor in the trough. Universal application: Liquor application to one or two sides or different liquor application on front and reverse side.
Applications:
 - Application of softener for terry fabric
 - Over dyeing or finishing of denim fabrics
 - Hydrophobing/hydrophilizing professional clothing
 - Stain-repellent finish of decoration fabrics
 - Functionalising (e.g. anti-smell) of outerwear



- Minimal Flottenauftragsaggregat mit angetriebenen Flottenwalzen. Die Alternative zum foulardieren. Zur energiebewussten, kostensparenden Trocknung. Kleine Flotteninhalte sichern geringe Restflottenmengen. Universelle Einsatzmöglichkeiten: einseitiger oder beidseitiger Flottenauftrag oder unterschiedlicher Flottenauftrag auf Vorder- und Rückseite.

Anwendungsgebiete:

- Weichmacher aufbringen für Frottierware
- Überfärben oder Appretieren von Denimware
- Hydrophob-/Hydrophilisierung von Berufsbekleidung
- Fleckschutz-Ausrüstung von Dekoware
- Funktionalisierung (z. B. antimuell) von Oberbekleidung



➤ Double Version ➤ Doppelaggregat

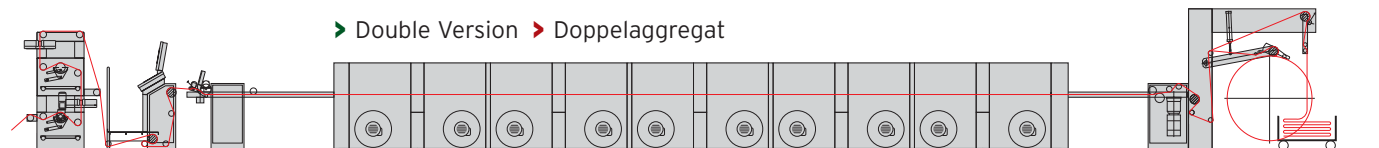



►Single Version ► Einzelaggregat

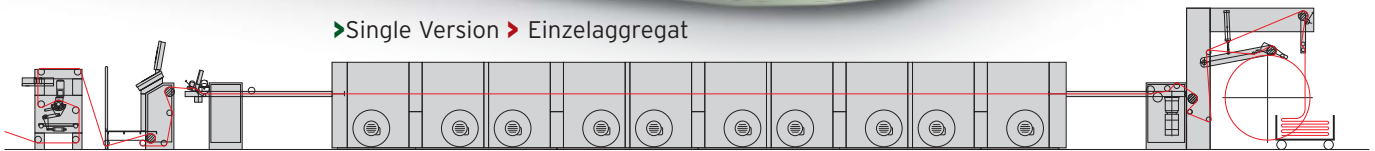



Monforts | Germany



Montex | Austria



Monforts Showroom | Germany



Monforts | China

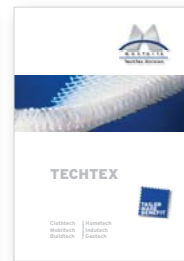
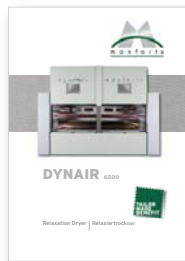
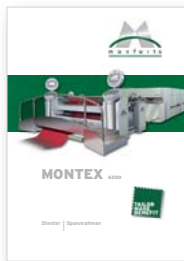

A. Monforts Textilmaschinen GmbH & Co. KG

Germany

Postfach 10 17 01
 Blumenberger Straße 143 -145
 Telefon:
 Telefax:
 Internet:
 eMail:

D-41017 Mönchengladbach
 D-41061 Mönchengladbach
 + 49 - (0) - 21 61 - 401-409
 + 49 - (0) - 21 61 - 401-498
 www.monforts.de
 info@monforts.de



A Possehl Company

